

Lecture – 9 & Lecture-10 (Dt. 16th April 2020)

Microwave Engineering (EC- 6th Sem)

Waveguide Tees, Directional Coupler, Etc.

The writer is not responsible for any legal issue arising out of any copyright demands and / or reprint issues contained in this material. This is not meant for any commercial purpose. This is solely meant for personal reference of students during Covid-19 following the syllabus prescribed by the university.

Acknowledgement

Special thanks to Prof. Dr. V Siva Nagaraju & Prof. Dr. V. Naresh Kumar, Dept. Of ECE, Institute of Aeronautical Engineering, Hyderabad for providing lecture notes.

WAVEGUIDE JUNCTION

Waveguide junctions are used when power in a waveguide needs to be split or some extracted. There are a number of different types of waveguide junction that can be use, each type having different properties - the different types of waveguide junction affect the energy contained within the waveguide in different ways.

When selecting a waveguide junction balances between performance and cost need to be made and therefore an understanding of the different types of waveguide junction is useful.

Waveguide junction types

There are a number of different types of waveguide junction. The major types are listed below:

- **H-type T Junction:** This type of waveguide junction gains its name because top of the "T" in the T junction is parallel to the plane of the magnetic field, H lines in the waveguide.
- **E-Type T Junction:** This form of waveguide junction gains its name as an E- type T junction because the top of the "T" extends from the main waveguide in the same plane as the electric field in the waveguide.
- **Magic T waveguide junction:** The magic T waveguide junction is effectively a combination of the E-type and H-type waveguide junctions.
- **Hybrid Ring Waveguide Junction:** This form of waveguide junction is another form of waveguide junction that is more complicated than either the basic E-type or H-type waveguide junction.

E-TYPE WAVEGUIDE JUNCTION

It is called an E-type T junction because the junction arm, i.e. the top of the "T" extends from the main waveguide in the same direction as the E field. It is characterized by the fact that the outputs of this form of waveguide junction are 180° out of phase with each other.

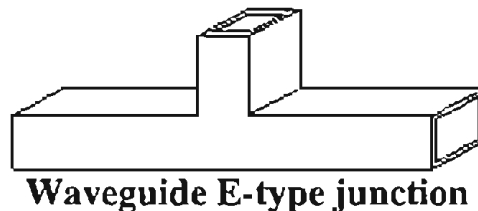

The basic construction of the waveguide junction shows the three port waveguide device. Although it may be assumed that the input is the single port and the two outputs are those on the top section of the "T", actually any port can be used as the input, the other two being outputs.

To see how the waveguide junction operates, and how the 180° phase shift occurs, it is necessary to look at the electric field. The magnetic field is omitted from the diagram for simplicity.

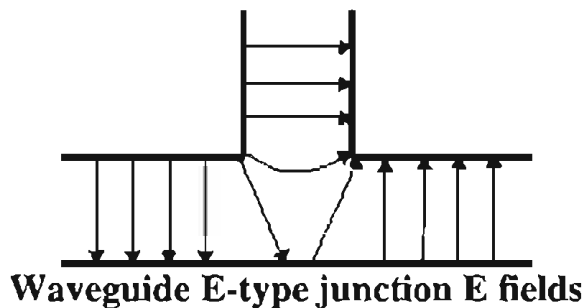

It can be seen from the electric field that when it approaches the T junction itself, the electric field lines become distorted and bend. They split so that the "positive" end of the line remains with the top side of the right hand section in the diagram, but the "negative" end of the field lines remain with the top side of the left hand section. In this way the signals appearing at either section of the "T" are out of phase.

These phase relationships are preserved if signals enter from either of the other ports.

H-TYPE WAVEGUIDE JUNCTION

This type of waveguide junction is called an H-type T junction because the long axis of the main top of the "T" arm is parallel to the plane of the magnetic lines of force in the waveguide. It is characterized by the fact that the two outputs from the top of the "T" section in the waveguide are in phase with each other.

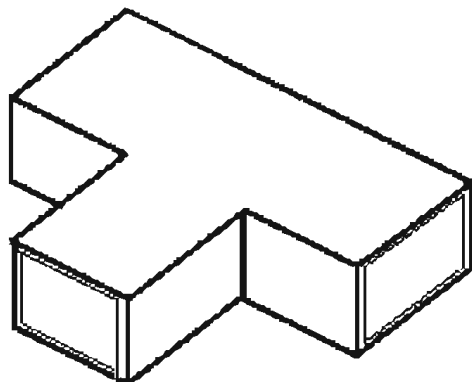

Waveguide H-type junction

To see how the waveguide junction operates, the diagram below shows the electric field lines. Like the previous diagram, only the electric field lines are shown. The electric field lines are shown using the traditional notation - a cross indicates a line coming out of the screen, whereas a dot indicates an electric field line going into the screen.

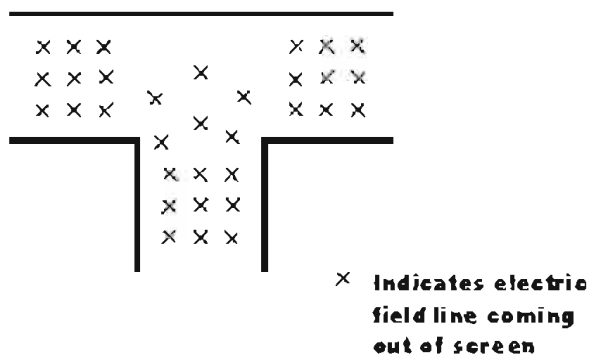

Waveguide H-type junction electric fields

It can be seen from the diagram that the signals at all ports are in phase. Although it is easiest to consider signals entering from the lower section of the "T", any port can actually be used - the phase relationships are preserved whatever entry port is used.

MAGIC T HYBRID WAVEGUIDE JUNCTION

The magic-T is a combination of the H-type and E-type T junctions. The most common application of this type of junction is as the mixer section for microwave radar receivers.

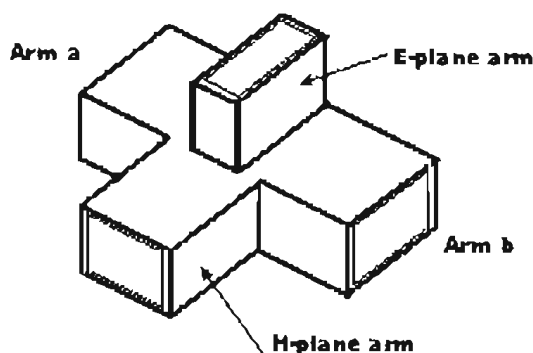

Magic T waveguide junction

The diagram above depicts a simplified version of the Magic T waveguide junction with its four ports.

To look at the operation of the Magic T waveguide junction, take the example of when a signal is applied into the "E plane" arm. It will divide into two out of phase components as it passes into the leg consisting of the "a" and "b" arms. However no signal will enter the "E plane" arm as a result of the fact that a zero potential exists there - this occurs because of the conditions needed to create the signals in the "a" and "b" arms. In this way, when a signal is applied to the H plane arm, no signal appears at the "E plane" arm and the two signals appearing at the "a" and "b" arms are 180° out of phase with each other.

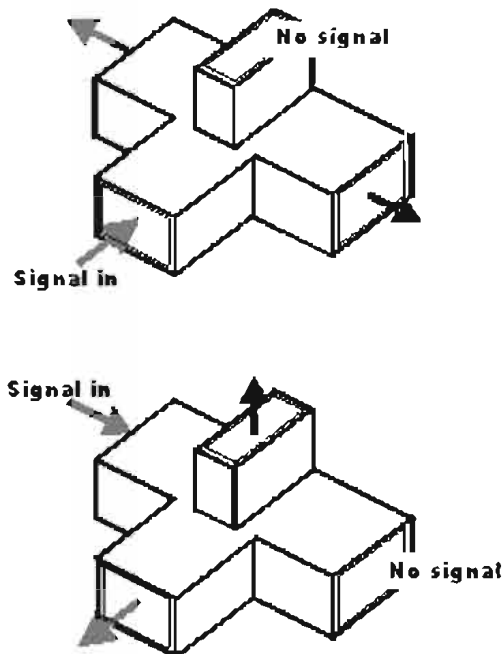

Magic T waveguide junction signal directions

When a signal enters the "a" or "b" arm of the magic t waveguide junction, then a signal appears at the E and H plane ports but not at the other "b" or "a" arm as shown.

One of the disadvantages of the Magic-T waveguide junction are that reflections arise from the impedance mismatches that naturally occur within it. These reflections not only give rise to power loss, but at the voltage peak points they can give rise to arcing when sued with high power transmitters. The reflections can be reduced by using matching techniques. Normally posts or screws are used within the E-plane and H-plane ports. While these solutions improve the impedance matches and hence the reflections, they still reduce the power handling capacity.

HYBRID RING WAVEGUIDE JUNCTION

This form of waveguide junction overcomes the power limitation of the magic-T waveguide junction.

A hybrid ring waveguide junction is a further development of the magic T. It is constructed from a circular ring of rectangular waveguide - a bit like an annulus. The ports are then joined to the annulus at the required points. Again, if signal enters one port, it does not appear at all the others.

The hybrid ring is used primarily in high-power radar and communications systems where it acts as a duplexer - allowing the same antenna to be used for transmit and receive functions.

During the transmit period, the hybrid ring waveguide junction couples microwave energy from the transmitter to the antenna while blocking energy from the receiver input. Then as the receive cycle starts, the hybrid ring waveguide junction couples energy from the antenna to the receiver. During this period it prevents energy from reaching the transmitter.

Waveguide junctions are an essential element within waveguide technology. Enabling signals to be combined and split, they find applications in many areas as discussed in the text. The waveguide T junctions are the simplest, and possibly the most widely used, although the magic-T and hybrid ring versions of the waveguide junction are used in particular applications where their attributes are required.

WAVEGUIDE FLANGES, COUPLERS AND TRANSITIONS

A signal can be entered into the waveguide in a number of ways. The most straightforward is to use what is known as a launcher. This is basically a small probe which penetrates a small distance into the centre of the waveguide itself as shown. Often this probe may be the centre conductor of the coaxial cable connected to the waveguide. The probe is orientated so that it is parallel to the lines of the electric field which is to be set up in the waveguide. An alternative method is to have a loop which is connected to the wall of the waveguide. This encompasses the magnetic field lines and sets up the electromagnetic wave in this way. However for most applications it is more convenient to use the open circuit probe. These launchers can be used for transmitting signals into the waveguide as well as receiving them from the waveguide.

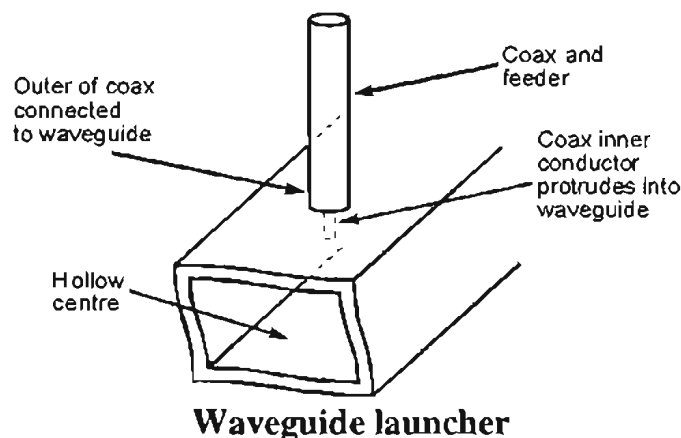

WAVEGUIDE BENDS

Waveguide is normally rigid, except for flexible waveguide, and therefore it is often necessary to direct the waveguide in a particular direction. Using waveguide bends and twists it is possible to arrange the waveguide into the positions required.

When using waveguide bends and waveguide twists, it is necessary to ensure the bending and twisting is accomplished in the correct manner otherwise the electric and magnetic fields will be unduly distorted and the signal will not propagate in the manner required causing loss and reflections. Accordingly waveguide bend and waveguide twist sections are manufactured specifically to allow the waveguide direction to be altered without unduly destroying the field patterns and introducing loss.

Types of waveguide bend

There are several ways in which waveguide bends can be accomplished. They may be used according to the applications and the requirements.

- Waveguide E bend
- Waveguide H bend
- Waveguide sharp E bend
- Waveguide sharp H bend

Each type of bend is achieved in a way that enables the signal to propagate correctly and with the minimum of disruption to the fields and hence to the overall signal.

Ideally the waveguide should be bent very gradually, but this is normally not viable and therefore specific waveguide bends are used.

Most proprietary waveguide bends are common angles - 90° waveguide bends are the most common by far.

Waveguide E bend

This form of waveguide bend is called an E bend because it distorts or changes the electric field to enable the waveguide to be bent in the required direction.

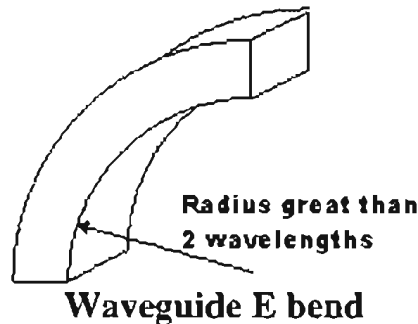

To prevent reflections this waveguide bend must have a radius greater than two wavelengths.

Waveguide H bend

This form of waveguide bend is very similar to the E bend, except that it distorts the H or magnetic field. It creates the bend around the thinner side of the waveguide.

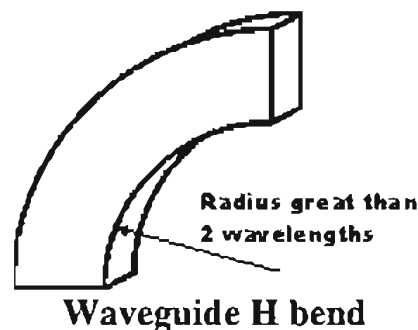

As with the E bend, this form of waveguide bend must also have a radius greater than 2 wavelengths to prevent undue reflections and disturbance of the field.

Waveguide sharp E bend

In some circumstances a much shorter or sharper bend may be required. This can be accomplished in a slightly different manner. The techniques are to use a 45° bend in the waveguide. Effectively the signal is reflected, and using a 45° surface the reflections occur in such a way that the fields are left undisturbed, although the phase is inverted and in some applications this may need accounting for or correcting.

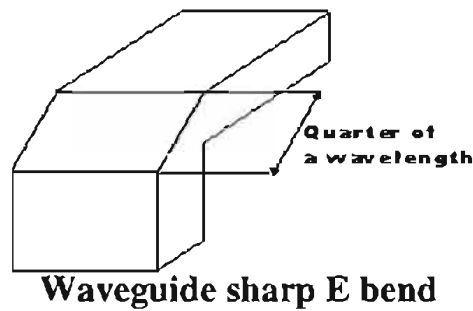

Waveguide sharp H bend

This form of waveguide bend is the same as the sharp E bend, except that the waveguide bend affects the H field rather than the E field.

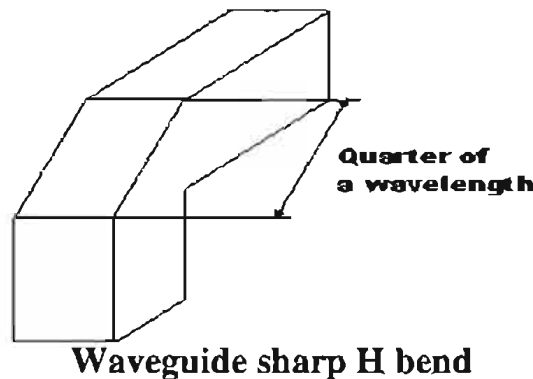

WAVEGUIDE TWISTS

There are also instances where the waveguide may require twisting. This too, can be accomplished. A gradual twist in the waveguide is used to turn the polarization of the waveguide and hence the waveform.

In order to prevent undue distortion on the waveform a 90° twist should be undertaken over a distance greater than two wavelengths of the frequency in use. If a complete inversion is required, e.g. for phasing requirements, the overall inversion or 180° twist should be undertaken over a four wavelength distance.

Waveguide bends and waveguide twists are very useful items to have when building a waveguide system. Using waveguide E bends and waveguide H bends and their strap bend counterparts allows the waveguide to be turned through the required angle to meet the mechanical constraints of the overall waveguide system. Waveguide twists are also useful in many applications to ensure the polarization is correct.

ATTENUATOR:

A *microwave circulator* is a multiport waveguide junction in which the wave can flow only from the n th port to the $(n + 1)$ th port in one direction (see Fig. 4-6-2). Although there is no restriction on the number of ports, the four-port microwave circulator is the most common. One type of four-port microwave circulator is a combination of two 3-dB side-hole directional couplers and a rectangular waveguide with two nonreciprocal phase

shifters as shown in Fig. 4-6-3.

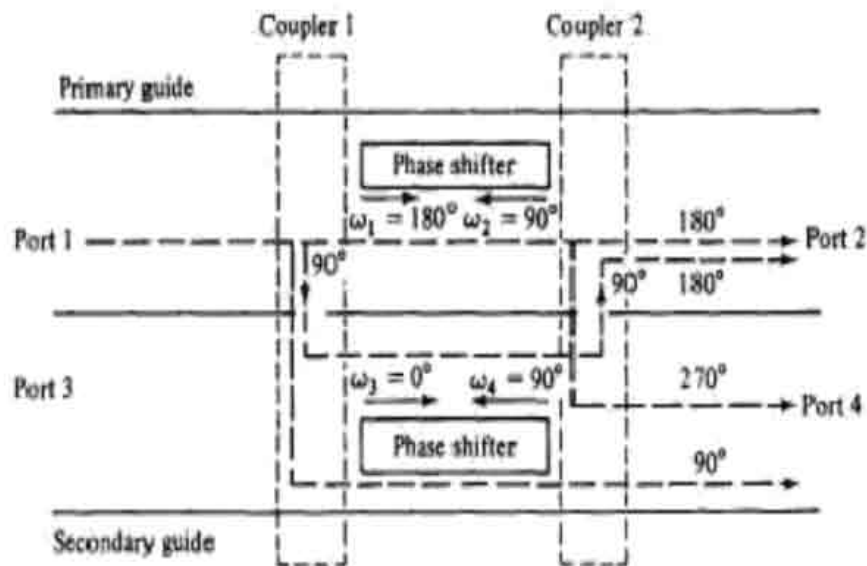

The operating principle of a typical microwave circulator can be analyzed with the aid of Fig. 4-6-3. Each of the two 3-dB couplers in the circulator introduces a phase shift of 90° , and each of the two phase shifters produces a certain amount of phase change in a certain direction as indicated.

When a wave is incident to port 1, the wave is split into two components by coupler 1. The wave in the primary guide arrives at port 2 with a relative phase change of 180° . The second wave propagates through the two couplers and the secondary guide and arrives at port 2 with a relative phase shift of 180° .

Since the two waves reaching port 2 are in phase, the power transmission is obtained from port 1 to port

2. However, the wave propagates through the primary guide, phase shifter, and coupler 2 and arrives at port 4 with a phase change of 270° . The wave travels through coupler 1 and the secondary guide, and it arrives at port 4 with a phase shift of 90° . Since the two waves reaching port 4 are out of phase by 180° , the power transmission from port 1 to port 4 is zero.

In general, the differential propagation constants in the two directions of propagation in a waveguide containing ferrite phase shifters should be where m and n are any integers, including zeros. A similar analysis shows that a wave incident to port 2 emerges at port 3 and so on. As a result, the sequence of power flow is designated as $1 \sim 2 \sim 3 \sim 4 \sim 1$. Many types of microwave circulators are in use today.

DIRECTIONAL COUPLERS:

A directional coupler is a four-port waveguide junction as shown in Fig. 4-5-1. It consists of a primary waveguide 1-2 and a secondary waveguide 3-4.

When all ports are terminated in their characteristic impedances, there is free transmission of power, without reflection, between port 1 and port 2, and there is no transmission of power between port 1 and port 3 or between port 2 and port 4 because no coupling exists between these two pairs of ports.

The degree of coupling between port 1 and port 4 and between port 2 and port 3 depends on the structure of the coupler. The characteristics of a directional coupler can be expressed in terms of its coupling factor and its directivity.

Assuming that the wave is propagating from port 1 to port 2 in the primary line, the coupling factor and the directivity are defined,

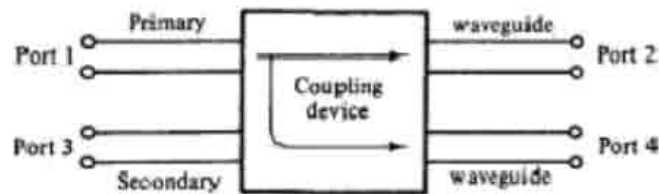

respectively, by

$$\text{Coupling factor (dB)} = 10 \log_{10} \frac{P_1}{P_4}$$

$$\text{Directivity (dB)} = 10 \log_{10} \frac{P_4}{P_3}$$

where P_1 = power input to port 1

P_3 = power output from port 3

P_4 = power output from port 4

It should be noted that port 2, port 3, and port 4 are terminated in their characteristic impedances. *The coupling factor* is a measure of the ratio of power levels in the primary and secondary lines. Hence if the coupling factor is known, a fraction of power measured at port 4 may be used to determine the power input at port

1. This significance is desirable for microwave power measurements because no disturbance, which may be caused by the power measurements, occurs in the primary line.
2. The directivity is a measure of how well the forward traveling wave in the primary waveguide couples only to a specific port of the secondary waveguide. An ideal directional coupler should have infinite directivity. In other words, the power at port 3 must be zero because port 2 and port 4 are perfectly matched.
3. Actually, well-designed directional couplers have a directivity of only 30 to 35 dB. Several types of directional couplers exist, such as a two-hole directional coupler, four-hole directional coupler, reverse-coupling directional coupler (Schwinger coupler), and Bethe-hole directional coupler (refer to Fig. 4-5-2). Only the very commonly used two-hole directional coupler is described here.

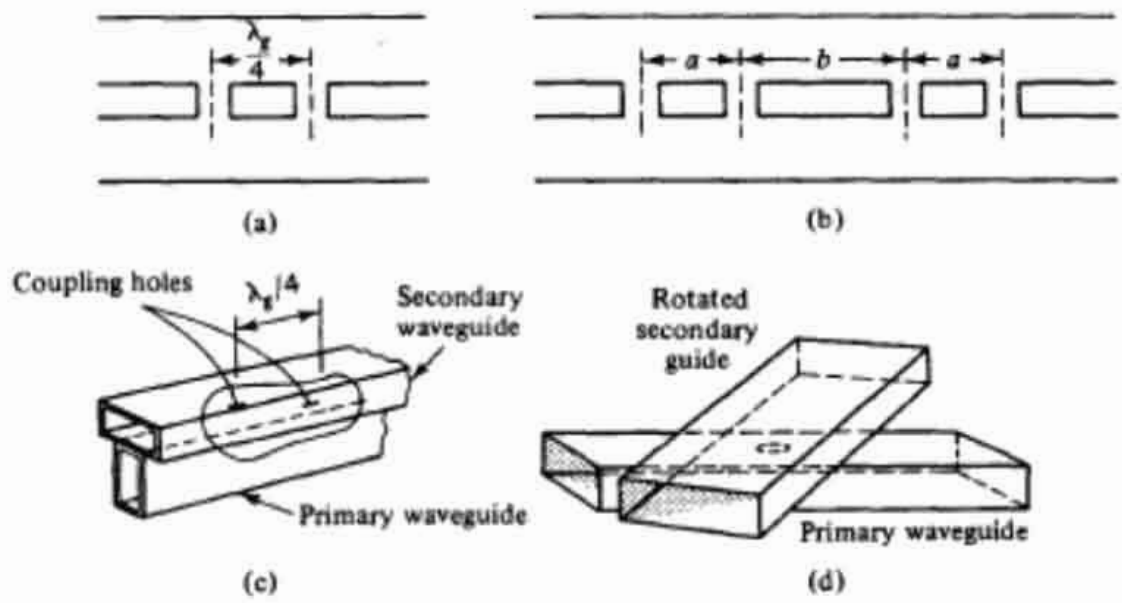

Figure 4-5-2 Different directional couplers. (a) Two-hole directional coupler. (b) Four-hole directional coupler. (c) Schwinger coupler. (d) Bethe-hole directional coupler.

$$S_{11} = S_{22} = S_{33} = S_{44} = 0$$

As noted, there is no coupling between port 1 and port 3 and between port 2 and port 4. Thus

$$S_{13} = S_{31} = S_{24} = S_{42} = 0$$

Consequently, the S matrix of a directional coupler becomes

$$S = \begin{bmatrix} 0 & S_{12} & 0 & S_{14} \\ S_{21} & 0 & S_{23} & 0 \\ 0 & S_{32} & 0 & S_{34} \\ S_{41} & 0 & S_{43} & 0 \end{bmatrix}$$

Equation (4-5-6) can be further reduced by means of the zero property of the S matrix, so we have

$$S_{12}S_{14}^* + S_{23}S_{34}^* = 0$$

$$S_{21}S_{23}^* + S_{41}S_{43}^* = 0$$

Also from the unity property of the S matrix, we can write

$$S_{12}S_{12}^* + S_{14}S_{14}^* = 1$$

Equations (4-5-7) and (4-5-8) can also be written

$$|S_{12}| |S_{14}| = |S_{23}| |S_{34}|$$

$$|S_{21}| |S_{23}| = |S_{41}| |S_{43}|$$

Since $S_{12} = S_{21}$, $S_{14} = S_{41}$, $S_{23} = S_{32}$, and $S_{34} = S_{43}$, then

$$|S_{12}| = |S_{34}|$$

$$|S_{14}| = |S_{23}|$$

Let

$$S_{12} = S_{34} = p$$

where p is positive and real. Then from Eq. (4-5-8)

$$p(S_{23}^* + S_{43}) = 0$$

Let

$$S_{23} = S_{41} = jq$$

where q is positive and real. Then from Eq. (4-5-9)

$$p^2 + q^2 = 1$$

The S matrix of a directional coupler is reduced to

$$S = \begin{bmatrix} 0 & p & 0 & jq \\ p & 0 & jq & 0 \\ 0 & jq & 0 & p \\ jq & 0 & p & 0 \end{bmatrix}$$

TWO HOLE DIRECTIONAL COUPLERS:

Two-Hole Directional Couplers

A two-hole directional coupler with traveling waves propagating in it is illustrated in Fig. 4-5-3. The spacing between the centers of two holes must be

$$L = (2n + 1) \frac{\lambda_g}{4}$$

where n is any positive integer.

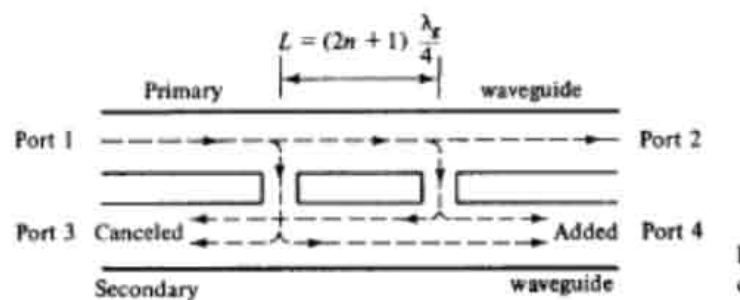

A fraction of the wave energy entered into port 1 passes through the holes and is radiated into the secondary guide as the holes act as slot antennas.

The forward waves in the secondary guide are in the same phase, regardless of the hole space, and are added at port 4.

The backward waves in the secondary guide (waves are progressing from right to left) are out of phase by $(2L/\lambda_g)2\pi$ rad and are canceled at port 3.

In a directional coupler all four ports are completely matched. Thus the diagonal elements of the S matrix are zeros

FERRITES:

An *isolator* is a nonreciprocal transmission device that is used to isolate one component from reflections of other components in the transmission line. An ideal isolator completely absorbs the power for propagation in one direction and provides lossless transmission in the opposite direction.

Thus the isolator is usually called *uniline*. Isolators are generally used to improve the frequency stability of microwave generators, such as klystrons and magnetrons, in which the reflection from the load affects the generating frequency.

In such cases, the isolator placed between the generator and load prevents the reflected power from the unmatched load from returning to the generator. As a result, the isolator maintains the frequency stability of the generator. Isolators can be constructed in many ways.

They can be made by terminating ports 3 and 4 of a four-port circulator with matched loads. On the other hand, isolators can be made by inserting a ferrite rod along the axis of a rectangular waveguide as shown in Fig. 4-6-5. The isolator here is a Faraday-rotation isolator. Its operating principle can be explained as follows [5]. The input resistive card is in the y - z plane, and the output resistive card is displaced 45° with respect to the input card.

The de magnetic field, which is applied longitudinally to the ferrite rod, rotates the wave plane of polarization by 45° . The degrees of rotation depend on the length and diameter of the rod and on the applied de magnetic field. An input TE₁₀ dominant mode is incident to the left end of the isolator. Since the TE₁₀ mode wave is perpendicular to the input resistive card, the wave passes through the ferrite rod without attenuation.

The wave in the ferrite rod section is rotated clockwise by 45° and is normal to the output resistive card. As a result of rotation, the wave arrives at the output