

B.tech Ag .Engg. Second Sem. Thermodynamics, Refrigeration and Air Conditioning Lectura 9- By- Yogesh Kumar

Topic- Vapour Absorption Refrigeration system-

The power utilized in vapour compression system is high grade energy i.e., electric power for running the compressor motor. In absorption refrigeration system, however, heat is directly utilized as source of energy. Of course, it may be preferable to utilize heat as such as it avoids undergoing through the various energy transformations required in the generation of electrical energy from heat energy.

It may be recalled that in the compression system the vapour was compressed by undergoing a great change in volume during the compression process. Accordingly the major part of the power was consumed in the process. If means were available for rising this pressure of the refrigerant without appreciably altering its volume, the work requirements will be enormously reduced (by about 95% or so).

This may possibly be done by dissolving the refrigerant in some absorbent and supplying the heat to the solution for compression purposes. The absorption cycle achieves this objective by placing the refrigerant in solution before the so called compression process and by removing from the solution immediately after the process. The absorption of the vapour is governed by Raoult's law.

The basic difference between vapour compression and vapour absorption cycles will thus be to replace the compressor of the vapour compression cycle by a set of equipment which fulfils the objective discussed above. The other important element i.e., condenser, expansion device and evaporator will exist in both systems.

Simple Vapour Absorption Cycle:

Figure 36.32 illustrates the simplest scheme of equipment required for the replacement of the compressor.

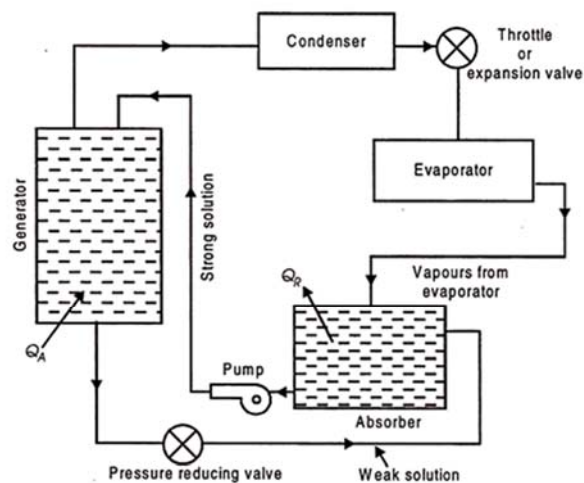

Fig. 36.32. Equipment replacing the compressor (Simple vapour absorption system of refrigeration)

Q_A = Heat added or supplied
 Q_R = Heat rejected to coolant.

Figure 36.32 equipment replacing the compressor (Simple vapour absorption system of refrigeration).

The most commonly used fluids in the absorption system are water as absorbent and ammonia as refrigerant. The vapour from the evaporator is allowed to be mixed and absorbed in the absorber. The heat of absorption generated in the process is rejected from the absorber to the circulating cold water in a heat exchanger dipped in the solution contained in the absorber.

The strong aqua-ammonia solution from the absorber is pumped upto the condenser pressure and fed to the generator which is the main energy consuming element of the system. Heat is supplied to the generator. The boiling point of refrigerant NH_3 , is lower than that of the absorbing liquid H_2O , hence the vapours leaving the generator are predominantly those of refrigerant.

These vapours then pass on to the condenser. The liquid refrigerant from the condenser, then, passes through an expansion valve or throttle valve to the evaporator where it absorbs heat from the substances or bodies to be refrigerated. Liquid refrigerant is then evaporated and the vapours enter the absorber completing the cycle.

The weak aqua-ammonia solution in the generator left due to separation of refrigerant vapour is drained back to the absorber for repeating the cycle.

The weak aqua-ammonia solution leaving the generator is at high pressure and the pressure in the absorber is the evaporator pressure which is less than the generator or condenser pressure, and hence a pressure reducing valve is provided in the weak solution line to the absorber.

The energy requirements of the system are at the generator and at the pump as compared to those at compressor in the vapour compression system. Since the volume of liquid handled by the pump is too small, the power required here is almost negligible as compared to that by the generator.

Practical Absorption Refrigeration Cycle:

The replacement of the compressor by the simple arrangement of Fig. 36.33 is not very economical in practice. In order to make improvements certain additional auxiliary items are provided in the system. They include analyzer, a rectifier, and two heat exchangers. The practical absorption cycles as developed after incorporating these auxiliaries is shown in Fig. 36.33.

(a) Analyzer: The ammonia vapours leaving the generator may contain certain moisture, and therefore it should be freed from any trace of water vapour before passing on to the condenser and then to the expansion valve, otherwise the water vapour is likely to freeze in the small valve passage and choke the flow.

The function of the analyzer is to remove the moisture as far as possible. It is an open type of cooler and forms an integral part of the generator, mounted on its top. Both the strong aqua-ammonia solution from the absorber and the condensate removed in rectifier are introduced from the top and flow downwards.

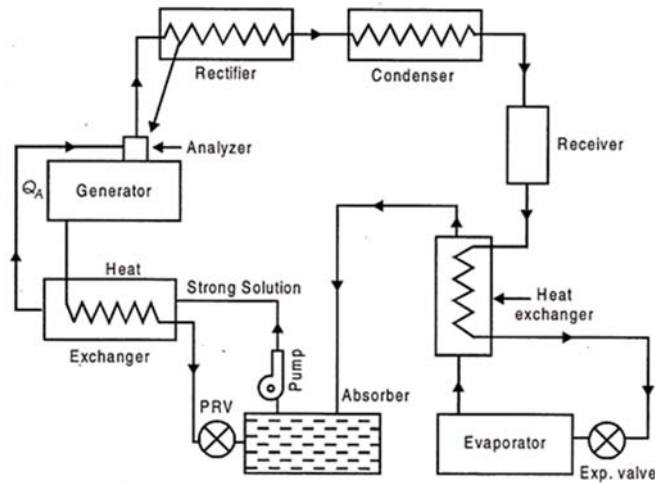

Fig. 36.33. Practical absorption system

The hot rising vapour of ammonia therefore comes in contact with the same and gets cooled. Thus most of the water vapour is condensed and drips back into the generator. This helps in salvaging a certain portion of heat in outgoing vapour which would otherwise have been rejected out through the condenser.

(b) Rectifier:

It is a closed type of cooler and is actually a miniature condenser where any traces of water vapour left in the ammonia vapour, are removed by condensation. The cooling is achieved by circulating water as is done in an ordinary condenser. The condensed aqua is drained back to the generator through the analyzer.

(c) Heat Exchangers:

Two heat exchangers are provided to internally exchange heat from the higher temperature fluid to the lower temperature fluid so that one is cooled and the other is heated.

One heat exchanger is provided between liquid receiver and evaporator so that the liquid is sub-cooled and vapour is heated up. Another heat exchanger is located between generator and absorber so that the strong aqua is heated up before going on to the analyzer and weak aqua is cooled before entering the absorber.

Performance of Vapour Absorption System:

Maximum coefficient of performance of heat operated vapour absorption system:

We know that refrigerant vapours are liberated from the strong solution when heated in a generator. This type of the machine or system is called a heat operated machine.

Let T_h be the temperature at which heat is supplied to the strong solution.

We will think of a system shown in Fig. 36.34.

T_k is the temperature at which heat is rejected to atmosphere; T_o is the temperature of the body to be refrigerated.

Thermal efficiency of the engine is given by-

$$\begin{aligned}\eta_{th} &= \frac{\text{Work}}{\text{Heat supplied}} \\ &= \frac{\text{Work}}{Q_h}\end{aligned}$$

$$\text{Work of the engine} = \eta_{th} \times Q_h$$

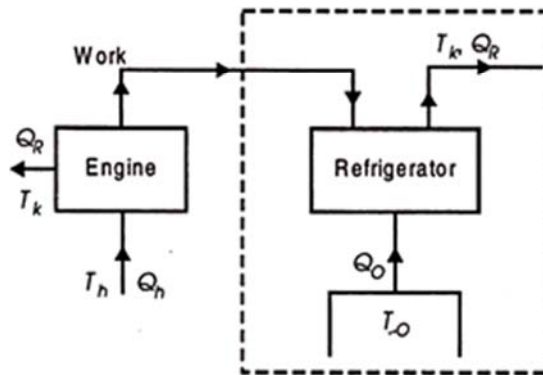

Fig. 36.34

This work, it is assumed, is used for refrigeration system.

For refrigeration system, T_o is the temperature at which heat is given to refrigerant (actually this is the heat abstracted from the body to be refrigerated) and the heat is rejected the atmosphere at T_k temperature.

To get the maximum COP, we have to consider the Carnot reversed engine.

$$(\text{COP})_{\text{carnot}} = \frac{T_o}{T_k - T_o} = \frac{Q_o}{Q_R - Q_o}$$

Similarly, we consider the engine as a Carnot engine and

$$(\eta_{\text{th}})_{\text{max}} = \frac{T_h - T_k}{T_h} = \frac{\text{Work}}{Q_h}$$

$$Q_o = (\text{COP})_{\text{carnot}} \times \text{Work}$$

and

$$Q_h = \frac{\text{Work}}{(\eta_{\text{th}})_{\text{carnot}}}$$

∴ COP of the cycle

$$= \frac{Q_o}{Q_h} = \frac{\text{Work} \times \eta_{\text{carnot}}}{\text{Work} / \eta_{\text{th}}}$$

$$= \eta_{\text{th}} \times \eta_{\text{carnot}}$$

This is maximum when η_{th} is maximum which is the Carnot thermal efficiency

$$(\text{COP})_{\text{max}} = (\eta)_{\text{carnot}} \times (\text{COP})_{\text{carnot}}$$

Note here that this maximum C.O.P. is not to be compared with COP of vapour compression system which is $\frac{Q_o}{W}$.

$$\therefore (\text{COP})_{\text{max}} = \frac{T_h - T_k}{T_h} \times \frac{T_o}{T_k - T_o}$$

In this case

T_h = Temperature of the source should be as high as possible (source temperature)

T_k = Sink temperature which should be as possible.

and

T_o = Refrigerator temperature should be as possible.